

The hoods with Hoisting hook

The hoods are bolted to the frame of the grab. A hoisting hook is mounted on each hood. Because the hoisting hooks are bolted they can easily be replaced.



Locking devices

The main pins are secured by the locking devices on one side being sunk into the bridge plate and the nuts on the other side being secured with a locking plate.

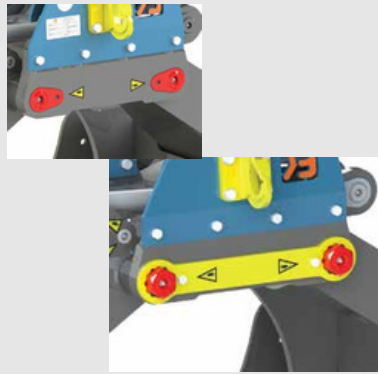

Double steady link

The BDVEZ L is equipped with two cross-placed steady links, which gives the grab extra stability and allows it to absorb more forces.

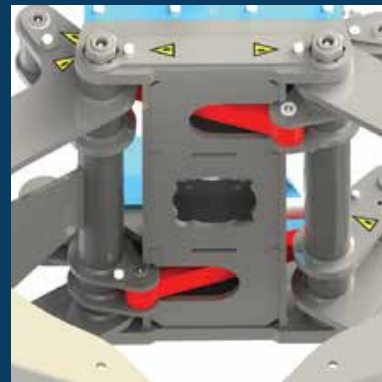

Type	Width	Capacity	Weight
BDVEZ L 090	92 cm	440 L	485 kg
BDVEZ L 100	102 cm	500 L	500 kg

BDVEZ L

Multi-purpose grab

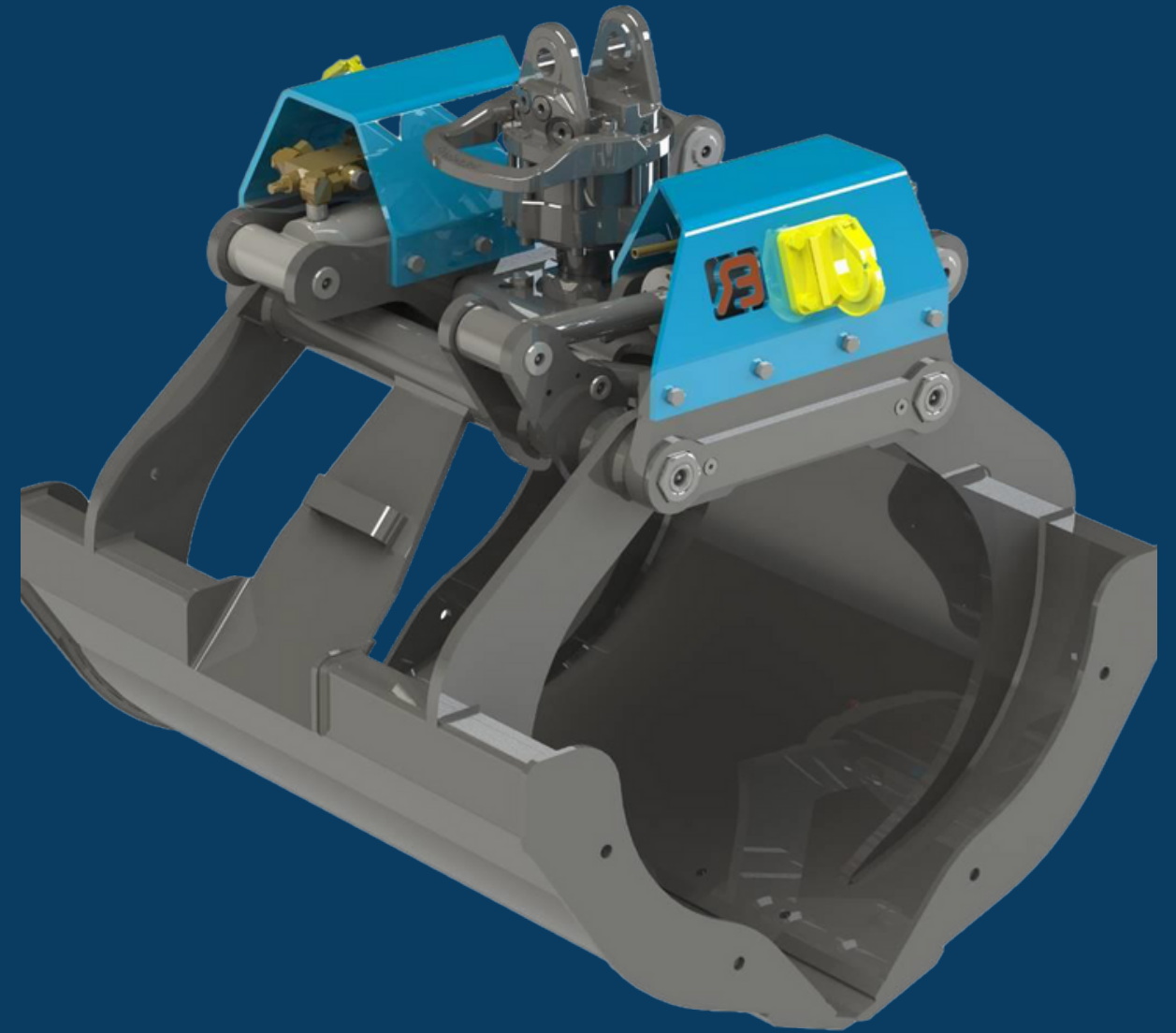

Grip opening

The BDVEZ L has a large grip opening that can also be used to pick up road plates up to 1500 mm, etc.

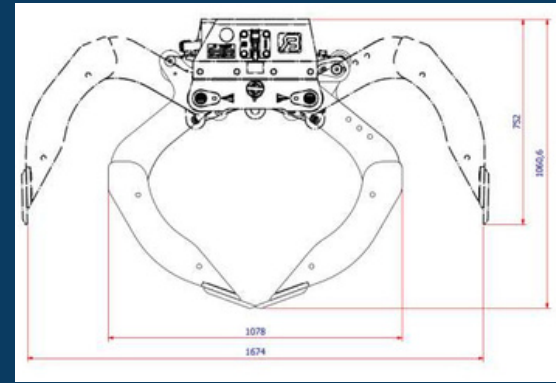

The hole pattern

The frame is equipped with the hole pattern for a rotator flange with 4 holes.

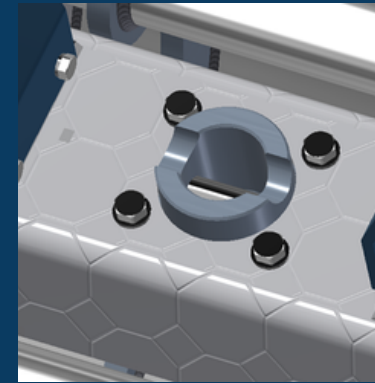

The extra lifting hook

An extra lifting hook is available as an option, which can be mounted in the middle under the bridge plate. The BDVEZ L therefore offers a lot of versatility.

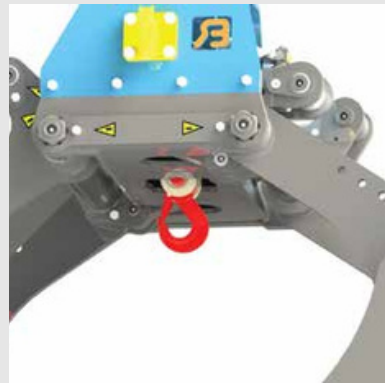

The interchangeable blades

The BDVEZ L is equipped as standard with wear-resistant interchangeable blades that are bolted to the shells. When the blades are worn, they can be unscrewed and turned over to use the other side.



Check valve

Due to a malfunction in the hydraulic system of the crane, the pressure in the cylinder can drop. To prevent the load from falling out of the grab in such situations, it is equipped with a non-return valve as standard.

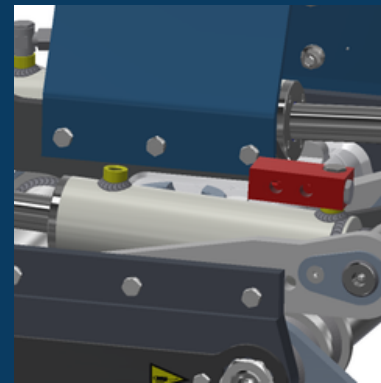

Mounting plate

To allow the grab to be folded onto the crane, one shell has a recess into which a plate with bracket is welded. The grab can be secured to a Z-crane when folding.



Accessories

For loading and unloading gravel, grit, etc., separate side plates are available as an option, which turns the BDVEZ L into a closed grab.

It is also possible to install a set of road plate segments. This turns your BDVEZ L into a road plate clamp that can easily pick up road plates with a width of up to 2000mm.

