

# LHH-4500

Container emptying system

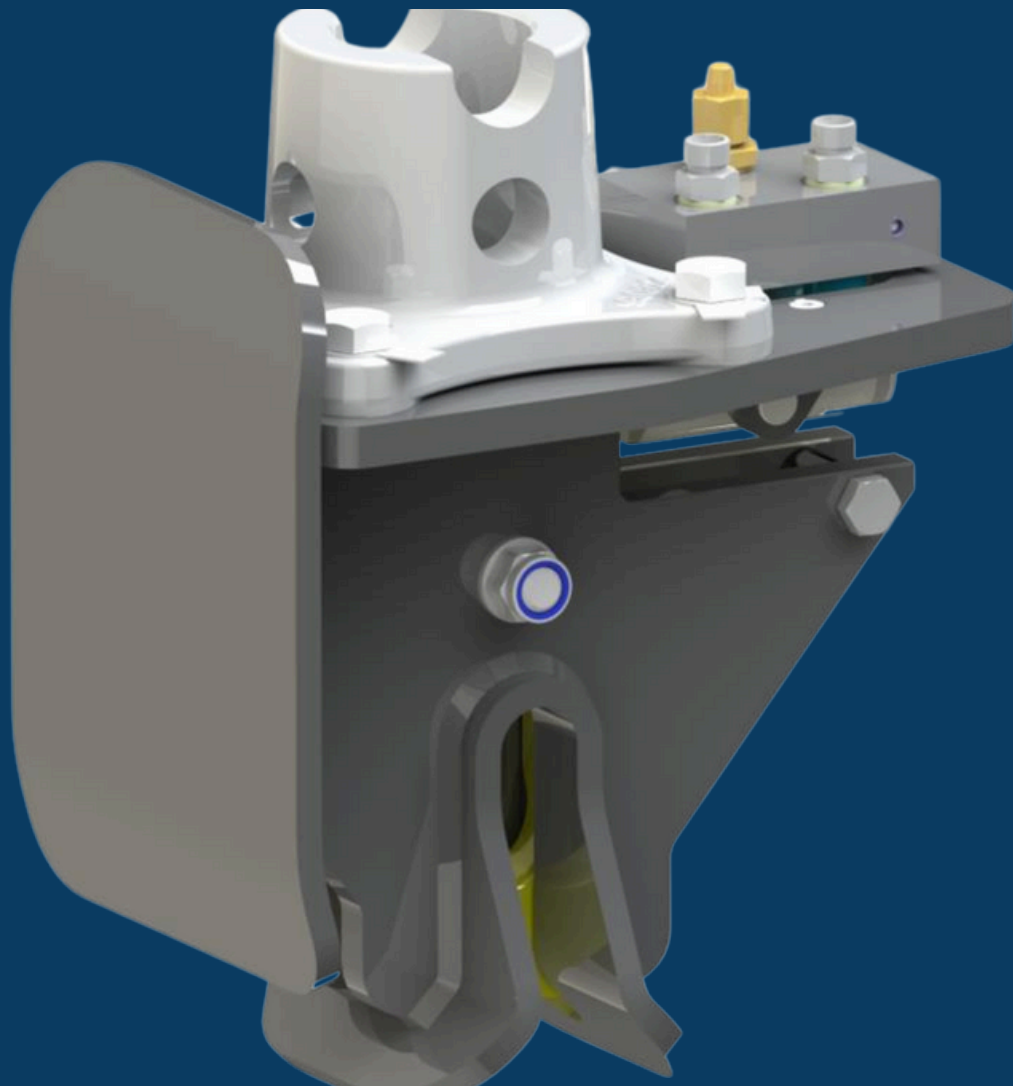

This container lifting system is designed for lifting containers with a single lifting hole instead of a bail. Like all our products, this LHH-4500 is equipped with a check valve and additional safety features. A CE certificate is included as standard, and a lifting certificate is available upon request.

**Accessoires:** Rotator, Link, suspension plate

Type	Additional hook	Duckbill lining	Weight Kg	Pressure Bar	Max oil flow L/Min	Safe workload Kg
LHH-4500 BR	No	Stainless steel	20	50	15	4500
LHH-4500 F BR	Yes	Stainless steel	20	50	15	4500
LHH-4500 BS	No	Steel	20	50	15	4500
LHH-4500 F BS	Yes	Steel	20	50	15	4500

